

# USA North's California Excavation Manual

811 / 1-800-227-2600 

Know what's below.  
Call before you dig.

- Overview: Page 1-6.
- Ticket Format: Page 6-7.
- Five Steps to a Safe Excavation: Page 7-8.
- No Response Follow-up Messages: Page 8-9
- Damage and Emergency Notification: Page 9
- Suggested Marking Guidelines: Page 10-21.

Disclaimer Notice: The suggested guidelines contained in this booklet are not intended to prevent excavators or operators from providing alternate forms of marking that are in accordance with California Government Code 4216. The suggested guidelines are representative in nature and do not address all delineation or facility markout situations.

**NOTE: The Following Two Bullets are California Law.**

- **California Business and Professions Code Section 7110:** Page 21.
- **California Government Code (CGC) 4216 requirements:** Page 22-30.
  - Outline your excavation area in white [4216.2 (a)] Page 25.
  - A 2 working day up to 14 calendar day (legal) notice is required before digging [4216.2 (a)] Page 25.
  - USA North will notify its members of your excavation [4216.2 (c)] Page 25.
  - The USA North members will by the legal notice mark or stake the horizontal path of their facilities, provide information about the location of their facility, or advise of clearance [4216.3 (a)] Page 26.
  - Expose the underground facilities by hand before using power equipment [4216.4 (a)] Page 27.
  - The USA North ticket number is valid for 28 calendar days. You must have an active USA North ticket number for the entire duration of your excavation [4216.2 (c)] Page 25.
  - Keep the USA North ticket number to validate your excavation permit [4216.9 (a)] Page 30.
- **CalOSHA Regulation Title 8 Chapter 4 Subchapter 4 Article 6 Section 1541:** Page 30-32

This manual is provided to you as a public service by USA North and is dedicated to the safety of our communities in California, and Nevada.

**Know what's below.  
Call 2 Working Days To 14 Calendar Days  
Before You Dig in California or Nevada!**



## OVERVIEW

USA North provides a free and effective Damage Prevention Service that protects our citizens, our communities, our environment, our essential public services, and our underground facilities in Central / Northern California and all of Nevada. USA North began operation in May of 1975 and incorporated as a Non Profit Mutual Benefit Corporation in 1986. Our purpose is to receive planned excavation reports that will begin within the next 14 calendar days from homeowners, excavators, or professional contractors and transmit those planned excavation reports to all participating members of USA North who may have facilities at that excavation site. Our members will 1) mark or stake the horizontal path of their facility, 2) provide information about the location of their facility, or 3) advise the caller of clearance, for facilities that they own.

### **USA North's Service Area:**

**Central & Northern California:** Alameda, Alpine, Amador, Butte, Calaveras, Colusa, Contra Costa, Del Norte, El Dorado, Fresno, Glenn, Humboldt, Kern, Kings, Lake, Lassen, Madera, Marin, Mariposa, Mendocino, Merced, Modoc, Mono, Monterey, Napa, Nevada, Placer, Plumas, Sacramento, San Benito, San Francisco, San Joaquin, San Luis Obispo, San Mateo, Santa Clara, Santa Cruz, Shasta, Sierra, Siskiyou, Solano, Sonoma, Stanislaus, Sutter, Tehama, Trinity, Tulare, Tuolumne, Yolo and Yuba.

**Nevada:** Carson City, Churchill, Clark, Douglas, Elko, Esmeralda, Eureka, Humboldt, Lander, Lincoln, Lyon, Mineral, Nye, Pershing, Storey, Washoe, and White Pine.

### **Common Ground - Study of One-Call Systems and Damage Prevention Best Practices:**

The United States Department of Transportation's Office of Pipeline Safety (OPS) initiated the Common Ground report under the authorization of the Transportation Equity Act for the 21<sup>st</sup> Century (TEA 21), Public Law 105-178, signed into law on June 9, 1998. The purpose of the study was to identify and validate existing best practices performed in connection with preventing damages to underground facilities. The Study ultimately resulted in a quality product that can be used to help in future efforts to improve underground damage prevention. The collected best practices should be shared among stakeholders involved with and dependent upon the safe and reliable operation, maintenance, construction, and protection of underground facilities.

### **Common Ground Chapters Titles:**

1. Introduction Practice Statements
2. Planning & Design Best Practices
3. One-Call Center Best Practices
4. Locating & Marking Best Practices

5. Excavation Best Practices
6. Mapping Best Practices
7. Compliance Best Practices
8. Public Education & Awareness Best Practices
9. Reporting & Evaluation Best Practices
10. Appendix A - Glossary of Terms & Definitions
11. Appendix B - Uniform Color Code & Marking Guideline
12. Appendix C - Sample Form for Reporting Damage Prevention Information
13. Appendix D - Additional References

For a complete version of the Common Ground Alliance Best Practices logon to [www.commongroundalliance.com](http://www.commongroundalliance.com) and download this information or order a copy.

**Common Ground Alliance Chapter 5 “Excavation Best Practices”:**

1. One-Call Facility Location Request
2. White Lining (CA & NV requires that you mark in white)
3. Locate Reference Number
4. Pre-excavation meetings
5. Facility Relocations
6. Separate Location Requests
7. One-Call Access (24x7)
8. Positive Response
9. Facility Owner / Operator Failure to Respond
10. Locate Verification
11. Documentation of Marks
12. Work Site Review with Company Personnel
13. One-Call Reference Number at Site
14. Contact Names and Numbers
15. Facility Avoidance
16. Federal and State Regulations
17. Marking Preservation
18. Excavation Observer
19. Excavation Tolerance Zone
20. Excavation within the Tolerance Zone
21. Mis-Marked Facilities
22. Exposed Facility Protection
23. Locate Request Updates
24. Facility Damage Notification
25. Notification of Emergency Personnel
26. Emergency Excavation
27. Backfilling
28. As-Built Documentation
29. Trenchless Excavation
30. Emergency Coordination with Adjacent Facilities

**Important Web Sites:**

- ◆ Common Ground Alliance / One Call Systems Int'l  
[www.commongroundalliance.com](http://www.commongroundalliance.com)
- ◆ USA North – (Call Before You Dig Center)  
[www.usanorth.org](http://www.usanorth.org)

- ◆ California Government Code [www.leginfo.ca.gov/cgi-bin/calawquery?codesection=gov&codebody=4216&hits=20](http://www.leginfo.ca.gov/cgi-bin/calawquery?codesection=gov&codebody=4216&hits=20)
- ◆ California Code of Regulations (Cal/OSHA) - [www.dir.ca.gov/title8/1541.html](http://www.dir.ca.gov/title8/1541.html)
- ◆ Nevada Revised Statutes - [www.leg.state.nv.us/NRS/NRS-455.html](http://www.leg.state.nv.us/NRS/NRS-455.html)
- ◆ Nevada Administration Code - [www.leg.state.nv.us/NAC/NAC-455.html](http://www.leg.state.nv.us/NAC/NAC-455.html)

**Be knowledgeable of all Federal, State, County, City, or Local Requirements:**

- Construction Code
- Contractor License Code
- Safety Code
- Franchise Code
- OSHA
- County, City or Local Ordinances
- Others that apply

**General Excavation Information:**

- Prior to starting an excavation, examine the excavation site for physical evidence (manholes, valve covers, water meters, sewer cleanouts, vaults, utility maintenance boxes, pole risers, etc) that would indicate the existence of underground facilities. Always excavate, as cautiously and prudently as possible.
- USA North accepts calls for excavation work on public or private property, on Military Bases, on Indigenous People's Reservations and even on waterways within our coverage area.
- Our members will mark or stake the horizontal path, provide information about the location, or provide clearance for facilities that they own. Excavators should be aware there could be other facilities of the same type at the excavation site owned by the property owner or another company who is not a member of USA North.
- When excavating within 10' of subsurface installations daylight the facility by hand every 25' to make sure the facility is where it is indicated. When excavating in CA or NV within 24" of a facility the law requires you to hand expose and protect the facility (it does not mean daylight or pothole) prior to using power equipment.
- Individuals with first hand knowledge of the excavation site and that can be reached by telephone should call the location description into USA North. This allows us, and our members, to discuss the location with a person who has knowledge of the excavation layout and specific location.
- Limit your excavation location description to a site that can be completed within a 28 calendar day period from

the date of your call to USA North in California or Nevada and that our members can reasonably locate within 2 working days.

- USA North limits excavation work to areas no longer in length than 1½ miles in a metropolitan area and 3 miles in a rural area.
- Dividing larger excavation areas into smaller manageable sites helps our members respond to your excavation site more promptly.
- As work in one excavation site nears completion, call in your next excavation site to USA North and continue this process until your entire excavation area is complete.
- When working on private property the excavator should determine what facilities belong to the property owner; (water, well, sewer, septic tanks, gas, propane lines, electrical, etc.) and what easement(s) may exist on the property, if any. In general, ownership of underground facilities transfers to the property owner behind the curb, behind the sidewalk, clean out, at the meter or point of demarcation.
- USA North notifies only its members of your excavation work, for your safety you should notify any non-member.

### **Excavation Types:**

**Special Note** - You will need to provide the City or Community that the excavation work is being done in and a verbal description of your excavation site. From your description, your Digsite will be built on the USA North base map to determine which of our members will be notified for that area. If your information is not accurate and correct the wrong members could be notified. It is critical that you provide USA North precise information about the location of the excavation, this is especially true when dealing with; New Streets, New Subdivisions or work off the roadway. If you are using distance or direction measurements, you should be accurate within 10 feet + or - with each measurement. To insure the accuracy of your location, provide the Latitude Longitude positions from a GPS device using NAD 83 CONUS decimal format.

#### I. Street/Address:

A. For an address provide:

- 1) Address and street name.
- 2) Two nearest streets that the address is between (system can take one street).
- 3) Where on the property you are digging?
- 4) How many feet from the street in front of your address is the work?

B. For multiple addresses provide:

- 1) Addresses and street name.
- 2) Two nearest streets that these addresses are between (system can take one street).
- 3) Where on the property you are digging?

- 4) How many feet from the street in front of your address is the work?

C. For a Street provide:

- 1) Street name and nearest intersecting street
- 2) Side of street with distance / direction

II. Intersections:

A. For an Intersection provide:

- 1) Street name and intersecting Street name.
- 2) Where in the intersection you are working?

B. For work at a single point from the Intersection provide:

- 1) Street name and intersecting street name.
- 2) Distance / direction to the point where the work will be.

C. For multiple points from an intersection (you may have to divide your excavation site into multiple locations that fit into four lines of text) provide:

- 1) Street name and intersecting street name.
- 2) Distance / direction to the first point where the work will be at;
- 3) From the first point provide the distance / direction to the second point where the work will be at;
- 4) From the second point provide the distance / direction to the third point where the work will be at;
- 5) From the third point provide the distance / direction to the fourth point where the work will be at.

D. For continuous work from an intersection provide (you may have to divide your excavation site into multiple locations that fit into four lines of text):

- 1) Street name and intersecting street name.
- 2) Distance / direction to the first point where you will be working to;
- 3) From the first point provide the distance / direction to the second point where you will be working to;
- 4) From the second point provide the distance / direction to the third point where you will be working to;
- 5) From the third point provide the distance / direction to the fourth point where you will be working to.

III. Between Intersections:

A. For work on a Street between intersections provide:

- 1) Street name.
- 2) Two intersecting Street names that the work is between.
- 3) Description of where on the Street you are working with distance / direction.

B. Multiple points on a Street between intersections provide:

- 1) Street name.
- 2) Two nearest Street names that the work is between.
- 3) Description of where on the Street you are working with distance / direction for each point.

C. For New Streets or New Subdivision (containing no streets on map within the excavation area) provide:

- 1) Street and nearest intersection outside the excavation.
- 2) Distance / direction to the new Street or Subdivision and a radius they are contained within.

IV. Bounded by Areas (containing no streets on map within the excavation area):

A. For Bounded Areas with Streets provide:

- 1) Street names that bound the area (2, 3 or 4 streets).

B. For Bounded Areas with streets and distances provide:

- 1) Street names that will be used as boundaries for the area.
- 2) Distance / direction from the one or two streets that will create the bounded in area.

---

### **USA North Ticket Format:**

- ✓ Business Phone Number:
- ✓ Fax Number:
- ✓ Email Address:
- ✓ Your Name:
- ✓ Your Company Name:
- ✓ Type:
- ✓ Industry:
- ✓ Company's Address:
- ✓ City:
- ✓ State:
- ✓ Zip:
- ✓ What County is your work being done in?
- ✓ Start Date: (a 2 working day to 14 calendar day notice is required)
- ✓ Start Time:
- ✓ Working For:
- ✓ As required has site been Premarked?
- ✓ Premarked method used?
- ✓ Permit Type:                      Permit #:
- ✓ Forman's Name:
- ✓ Cell Telephone:                      Field Telephone:
- ✓ Does your excavation include boring, if so what type?
- ✓ Type/Nature of Work: (augering, drilling, grading, ripping, trenching, etc.)

- ✓ Will Explosives be used at your work site?
- ✓ Do you intend to use vacuum equipment instead of hand digging to determine the exact location of our member's underground facilities?
- ✓ Digsite Place: (City or Community)
- ✓ Digsite Types: Address(s) between 2 nearest Sts, Street between 2 nearest Sts, Street & nearest St, Intersection or Bounded by Area that contains no Streets; include side of street, footages, other tie in measurements, or lat/long in NAD 83 CONUS decimal format).
- ✓ Will the excavation enter into the street or sidewalk area?
- ✓ Ticket #:
- ✓ Date of Call:
- ✓ Ticket Expiration Date:
- ✓ Update your ticket by:

Calling hours are from 6am-7pm Monday - Friday excluding weekends and the following holidays: New Year's Day, President's Day, Memorial Day, Independence Day, Labor Day, Thanksgiving Day, Day after Thanksgiving, and Christmas. USA North takes excavation notices in Central / Northern California and all of Nevada. Each ticket is active for 28 calendar days in California and Nevada from the date of its issuance. If you excavate and damage facilities prior to our member's response, you may be liable for those damages. After our members have responded to your request, it is your responsibility to notify USA North if you need our member(s) to re-mark their facilities. To minimize graffiti we recommend the use of spray chalk, water base, or UV paint by excavators and operators to identify their excavation site or subsurface installations respectively.

---

### **Five Steps to a Safe Excavation:**

1. **Survey and Mark:** Survey your proposed excavation site. Make a list of affected operators of underground facilities (operators) at your job site, their needs and requirements. Mark the excavation site on paved surfaces with white spray chalk, water base, UV paint or equivalent less permanent type marking; use flags, stakes, whiskers, etc. on unpaved surfaces, (Homeowners can use flour).

2. **Call Before You Dig:** Call USA North 2 working days to 14 calendar days (legal notice) before you dig in California or Nevada. Only operators who are members of the USA North program will be notified. Compare your list of affected operators determined in Step 1, with the list of operators notified by USA North. For your safety contact any operator at your job site that is not a member of USA North. USA North accepts design inquiry requests through its internet application only, call 925-798-9504 ext 2309 for more information.

3. **Wait the Required Time:** The legal 2 working days to 14 calendar days notice in California and Nevada allows USA North members to examine their underground facility records and respond to you. Our members, who are operators of underground facilities, will mark, or stake the horizontal path of their facility with the appropriate color code, provide you information about the location of their facility, or advise you of clearance. Depending on our member's workload, they may contact you to try to negotiate a new start time for your excavation. This will allow them the opportunity to provide you with greater service.

4. **Respect the Marks:** Preserve facility marks for the duration of the job. If any of the operator markings are not reasonably visible, you must call USA North and request re-marking by the affected operator(s). A re-mark request requires a 2 working day notice. When you request an operator(s) to re-mark their facilities, you will be asked if your excavation site is still outlined in white, so the USA North members can respond to your request.

Note: A USA North ticket is active for 28 calendar days in California and Nevada from the date of its issuance. You must have an active USA North ticket for the entire duration of your excavation.

5. **Dig With Care:** In California and Nevada hand excavate within 24" of the outside diameter of the facility. Facilities that are in conflict with your excavation are to be located with hand tools and protected before power equipment is used. Notify the affected utility of any contact, scrape, dent, nick or damage to their facility.

---

### **No Response Follow-Up:**

This process starts when the excavator notifies USA North that:

- A 2 working day to 14 calendar day (legal) notice was provided on the original ticket and,
- The start date/time has past and,
- A member(s) failed to respond to the excavation site by the legal start date & time of the ticket.

When a member successfully negotiates a new start date/time with an excavator, the negotiated start date/time becomes the legal start date/time for that excavation notice.

Once the start date/time has past, the excavator should determine if all USA North members have responded. The members will: mark or stake the horizontal path of their facilities, provide information about the location of their facilities, or advise of clearance. If the excavator determines that a member(s) of USA North has failed to respond in one of these manners the following steps are to be taken.

1) **First No Response Follow-up:** Call USA North after the original or agreed upon legal start date/time, that the work was to begin, and request USA North to send a

“First No Response Follow-up” to the member(s) (name the particular member(s)) that failed to respond to your notice. Request the member(s) to call and respond ASAP or call and provide clearance.

**2) Second No Response Follow-up:** Wait at least an hour or more, from your last call, to provide our member(s) an opportunity to call and respond to your first request. After this time has past and the member(s) still has not contacted you, call and request USA North to send a “Second No Response Follow-up” to the member(s) (name the particular member(s)) that has failed to respond to your notice. Request the member(s) to call and respond ASAP or call and provide clearance.

**3) Third No Response Follow-up:** Wait at least an hour or more, from your last call, to provide our member(s) an opportunity to call and respond to your second request. After this time has past and the member(s) still has not contacted you, call and request USA North, to send a “Third No Response Follow-up” to the member(s) (name the particular member(s)) that has failed to respond to your notice. Request the member(s) to call and respond ASAP or call and provide clearance. Note; the Center will attempt to make a call to the member(s) terminal involved and ask the member(s) to respond ASAP once the Third No Response Follow-up message has been transmitted.

**Warning:** There may be unidentified underground facilities at your job site. The excavator should review the job site for physical evidence of facilities not located, i.e. manholes, valve covers, water meters, sewer cleanouts, vaults, drains, fire hydrant, utility maintenance boxes, pole risers, or other facility indicators such as pavement patches etc.

---

### **Damage / Exposed Notification:**

- An excavator discovering or causing damage to a sub-surface installation shall notify the operator of the installation and USA North.
  - USA North accepts damage / exposed notices from the excavator and transmits the notice to our members in the area of the damage. USA North will also provide the excavator with the emergency telephone number for the member whose facility was damaged.
- 

### **Emergency Notification:**

- If the damage results in the escape of any flammable, toxic, or corrosive gas or liquid or endangers life, health or property, the excavator responsible immediately notifies 911 and the facility owner/operator.
- The excavator takes reasonable measures to protect themselves and those in immediate danger, general public, property, and the environment until the facility owner / operator or emergency responders have arrived and completed their assessment.

## Suggested Guidelines for Prospective Excavation Site Delineation and Facility Operator Location Markout

### General Guidelines

This guide provides for temporary uniform surface marking of both planned excavations and of substructures in potential conflict of planned excavations. White markings are used for excavation delineation. Substructure markings are of a specific color. Appropriate color and common abbreviations are listed herein. Full facility operator and excavator responsibilities are detailed in California Government Code (CGC) 4216 through 4216.9 and California Code of Regulations (Cal/OSHA) Title 8 Section 1541.

Note: Temporary markings should be clearly seen, functional, and considerate to surface aesthetics and the local community. Also, check to see if any local ordinances apply. It is recommended that each operator and excavator use a consistent marking standard.

#### **Marking In Paved Areas**

Avoid excessive or oversized marking, especially if marking outside the excavation area. Conditions permitting, use spray chalk paint, water based paint, UV paint, or equivalent less permanent type marking. Limit length, height, and interval of marks to those recommended in this manual. Letters and numbers should not exceed 3" to 6" in height.

#### **Marking in Non-Paved Areas**

The use of appropriately colored flags, stakes, whiskers, or chalk lines should be used in non-paved areas. Select marker types that are most compatible to the purpose and marking surface. Adhere to paved area marking suggestions to the extent practical.

If any marking information is omitted due to site conditions, communicate omitted data by direct contact, signs, phone, fax, etc.

"Offset" markings should clearly indicate the direction, the distance, and the path of facility or excavation.

#### **Marking Removal**

We recommend that the permitting agency (Local, City, County, State, or Federal) require the permittee to remove all marking paint or other suitable markings at the conclusion of the excavation. Included are all excavator and utility operator (operator) markings that resulted from the project. This recommendation is based on the fact that the excavator has the knowledge of the specific area and limits of the excavation; they are required under CGC 4216.2. (a) (1) to outline their excavation in white paint or other suitable markings; they requested to have the operators mark the

facilities which interface with the excavation; and they have the knowledge of when the excavation is completed. This will help eliminate graffiti on our streets and sidewalks caused by these markings and stop the erroneous use of out-dated operator's markings by other excavators.

### **Permitting Agencies**

We also recommend that permitting agencies (Local, City, County, State, or Federal) make excavators aware when multiple excavation permits are taken out for the same period of time and area. The agencies should advise each excavator that other excavators will be working within the same area and encourage them to communicate with one another so they do not destroy each other's excavation site markings or the markings of the operators responding to the multiple excavation sites.

### **Excavators**

Excavators should be specific when providing the description of the excavation area to USA North and when outlining their excavation area in white chalk paint or other suitable markings. This will help the operators to respond to the exact area of excavation and minimize their markings.

- Excavator's pre-marking (delineation) of the excavation site is a requirement of CGC 4216 and CalOSHA 1541.
- Delineate the area to be excavated before calling USA North. Delineated areas should be identified in white markings with the requester's company identifier (name, abbreviations or initials) within the pre-marked zones (see examples).
- Failure to pre-mark when practical may jeopardize your permit, or result in civil penalties.
- CGC 4216.2 (f) requires: "If pre-marking is not practical, the excavator shall contact" USA North "to advise the operators that the excavator shall identify the area to be excavated in another manner sufficient to enable the operator to determine the exact area of the excavation to be field marked."
- CGC 4216.2 (e) states delineation must not be misleading, duplicative or misinterpreted as traffic or pedestrian control.

### **Operators**

To increase the accuracy of the locates when the facilities run through utility maintenance boxes, manholes, valve covers, splice boxes etc have your locators pull the lids to determine how many facilities enter and leave the boxes and which direction the facilities run. Operators marking outside the white outlined excavation area should include the USA North ticket number with their marks to identify which excavation site their marks were provided for.

## CGA Guidelines For Excavation Delineation

The following marking illustrations are examples of how excavators may choose to mark their area of proposed excavation. The use of white marking products (e.g. paint, flags, stakes, whiskers or a combination of these) may be used to identify the excavation site.

### Single Point Excavations Markings

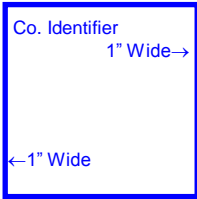

**Full Line**

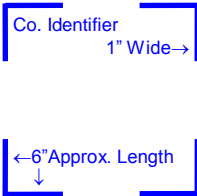

**Four Corner**

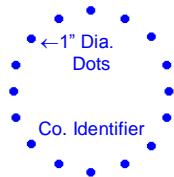

Dots to be less than 4' spacing

**Radius or Arc**

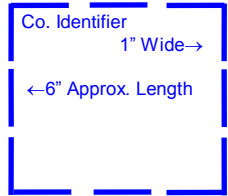

**Dash Line**

Delineate in white products the proposed area of excavation through the use of: a continuous line, dots marking the radius or arcs, dashes marking the four corners of the project or dashes outlining the excavation project. Limit the size of each dash to approximately 6" to 12" in length and 1" in width with interval spacing approximately 4' to 50' apart. The maximum separation of excavation marks is to be reduced to a length that can be reasonably seen by the operator's locators when the terrain or excavation site conditions warrant it. Dots of approximately 1" diameter are typically used to define arcs or radii and may be placed at closer intervals in lieu of dashes.

### Single Stake Marking Center Point of Excavation Site

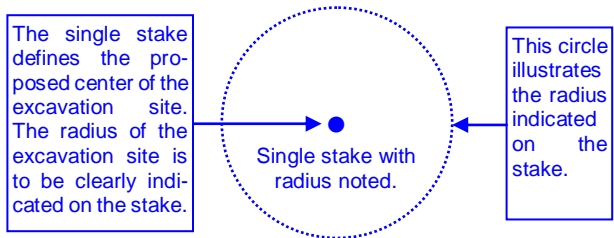

When an excavation site is contained within a 50' maximum radius, or less, it can be delineated with a single stake that is positioned at the proposed center of the excavation. If the excavator chooses this type of delineation they must convey that they have delineated the excavation site with a single stake at the center of the excavation and include the radius of the site in the notification to the One-Call Center. This single stake is to be white in color with the following information: excavator's company identifier (name, abbreviations, or initials) and the radius of the excavation site in black letters on the stake or with a notice attached to the stake.

**Trenching, Boring, or Other  
Continuous Types of Excavations**

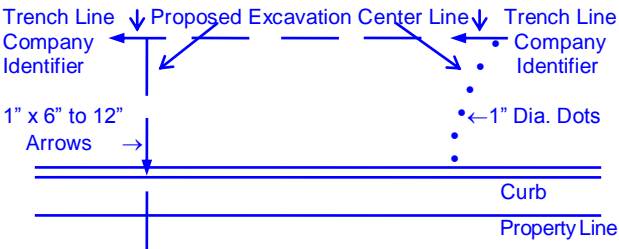

**Continuous Excavation Marking**

Mark in white paint the proposed centerline of planned excavation 6" to 12" x 1" arrows, approximately 4' to 50' apart to show direction of excavation. The maximum separation of excavation marks is to be reduced to a length that can be reasonably seen by the operator's locators when the terrain at an excavation site warrants it. Mark lateral excavations with occasional arrows showing excavation direction from centerline with marks at curb or property line if crossed. Dots may be used for curves and closer interval marking.

**Stakes, Flags or Whiskers Excavation Markers**

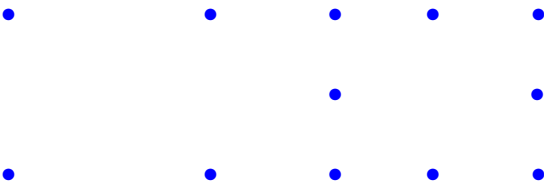

**Stakes, Flags or Whiskers  
Marking Four Corners**

**Stakes, Flags or Whiskers  
Marking Outline of Excavation**

Delineate the proposed area of excavation through the use of: stakes, flags or whiskers to mark radius or arcs, the four corners of the project or outlining the excavation project instead of using spray paint. Limit the interval spacing to

approximately 4' to 50'. The maximum separation of excavation marks is to be reduced to a length that can be reasonably seen by the operator's locators when the terrain at an excavation site warrants it. Stakes, flags or whiskers provided to illustrate arcs or radii may be placed at closer intervals in order to define the arc or radius. Stakes, flags or whiskers are white in color with the excavator's company identifier (name, abbreviations, or initials) provided on the stake, flag or whisker.

## CGA Guidelines For Operator's Facility Field Delineation

Operator markings of facilities include; the appropriate color for their facility type; their company identifier (name, initials, or abbreviation) when other companies are using the same color, the number and width of their facilities and a description of the facility (HP, FO, STL etc). Use paint, flags, stakes, whiskers or a combination to identify the operator's facility(s) at or near an excavation site.

- 1 Marks in the appropriate color are to be approximately 12" to 18" in length and 1" inch in width and separated by approximately 4' to 50' in distance as an example. When marking facilities the operator is to consider the type of facility being located, the terrain of the land, the type of excavation being done and the method to adequately mark its facilities for the excavator.

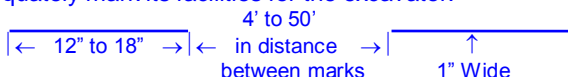

- 2 The following marking illustrations are examples of how an operator may choose to mark their subsurface installations

- a **Single Facility Marking:** Used to mark a single facility, marks are placed over the approximate center of the facility. This example indicates an operator's 12" facility. When a facility can be located or toned separately from other facilities of the same type it is marked as a single facility.

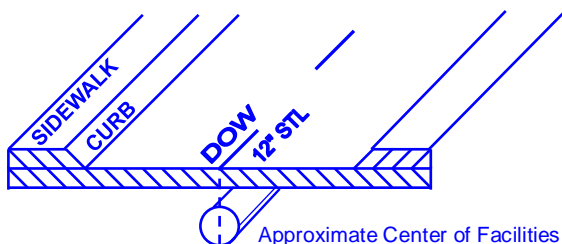

- b Multiple Facility Marking:** Used to mark multiple facilities of the same type (e.g. electric), where the separation does not allow for a separate tone for each facility but the number and width of the facilities is known. Marks are placed over the approximate center of the facilities and indicate the number and width of the facilities. This example indicates 4 plastic facilities that are 4" in diameter (4/4" PLA).

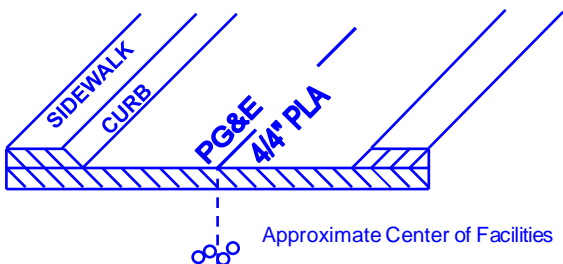

- c Conduit Marking:** Used for any locatable facility being carried inside conduits or ducts. The marks indicating the outer extremities denote the actual located edges of the facilities being represented. An example would be 4 plastic conduits that are 4" in diameter (4/4" PLA), and the marks are 16" apart indicating the actual left and right edges of the facilities.

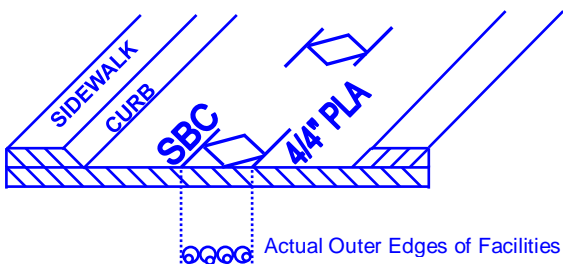

- d Corridor Marking:** Used to mark multiple facilities of the same type (e.g. electric), in the same trench where the total number of facilities is not readily known (operator has no record on file for the number facilities) and that are bundled or intertwined. Marks are placed over the approximate center of the facilities and indicate the width of the corridor. The width of the corridor is the distance between the actual located outside edges of the combined facilities. This example indicates a 12" corridor (12" CDR).

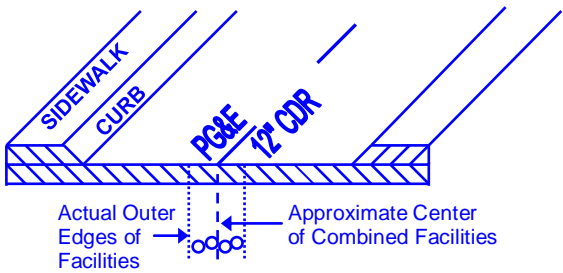

- 3** Changes in direction, and lateral connections are to be clearly indicated at the point where the change in direction or connection occurs with an arrow indicating the path of the facility. A radius is indicated with marks describing the arc. When providing offset markings, (paint or stakes), show the direction of the facility and distance to the facility from the markings.

**Radius Example!**

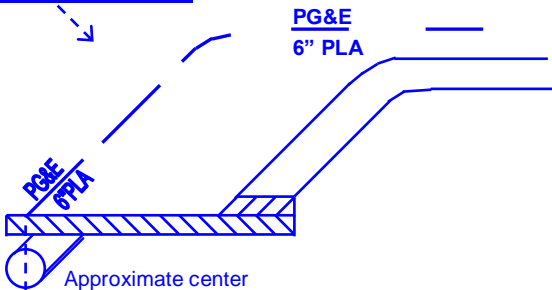

**Lateral Connection Example!**

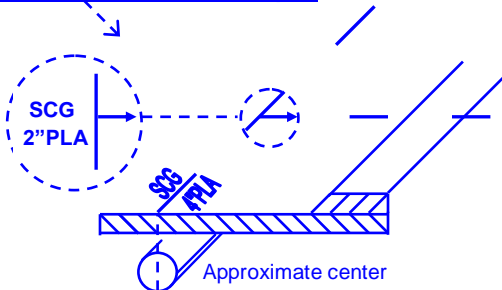

### Painted Offset (off) Example!

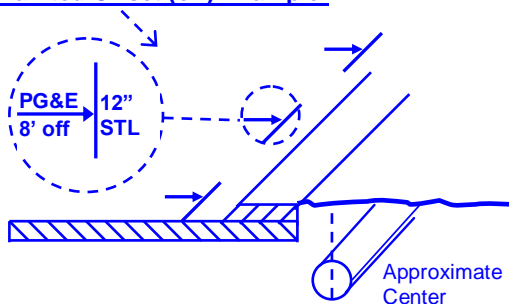

### Staked Offset (off) Example!

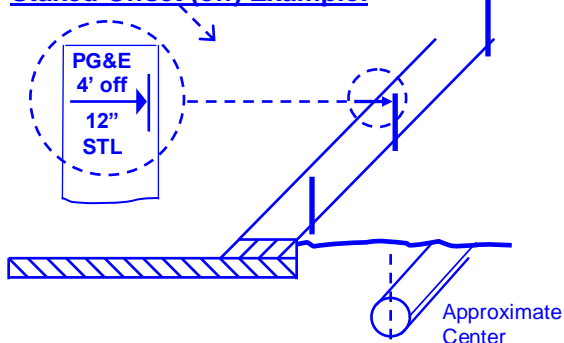

- 4** An operator's identifier (name, abbreviation or initials) is to be placed at the beginning and at the end of the proposed work. In addition to the previous, subsequent operators using the same color, will mark their company identifier at all points where their facility crosses another operator's facility using the same color. The maximum separation of identifiers is to be reduced to a length that can be reasonably seen by the excavator when the terrain at the excavation site warrants it.

CTYSAC

CITIZENS

VERIZON

- 5** Information as to the size and composition of the facility is to be marked at an appropriate frequency. Examples are: the number of ducts in a multi-duct structure, width of a pipeline, and whether it is steel, plastic, cable, etc.

CCWD  
4" PLA

RSVTEL  
9 PLA

DOW  
12" STL

- 6 Facilities installed in a casing should be identified as such. Two examples are: 6" plastic in 12" steel = 6"PLA/12"STL and fiber optic in 4" steel = FO(4"STL).

ACWD  
6"PLA/12"STL

AT&T  
FO(4"STL)

- 7 Structures, such as vaults, inlets, lift stations that are physically larger than obvious surface indications, are to be marked so as to define the parameters of the structure.

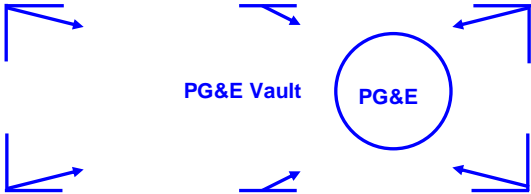

- 8 Termination points or dead ends should be indicated as such.

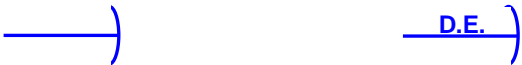

- 9 When there is "No Conflict" with the excavation complete one or more of the following:

- Operators of a single type of facility (e.g. AT&T) would mark the area "NO" followed by the appropriate company identifier in the matching APWA color code for that facility (e.g. "NO AT&T")
- Operators of multiple facilities would mark the area "NO" followed by the appropriate company identifier in the matching APWA color code for that facility with a slash and the abbreviation for the type of facility that there is "No Conflict" (e.g. "NO PG&E/G/D"). The example illustrates that PG&E has no gas distribution facilities at this excavation site. The abbreviation for; gas transmission facilities is "/G/T", electric distribution is "/E/D" and electric transmission is "/E/T" these should be used when appropriate.
- Place a clear plastic (translucent) flag that states "No Conflict" in lettering matching the APWA color code of the facility that is not in conflict. Include on the flag the operator's identifier, phone number, a place to write the locate ticket number and date. Operators of multiple facilities would indicate on the flag, which

facilities were in “No Conflict” with the excavation as in the previous example.

- If it can be determined through maps or records that the proposed excavation is obviously not in conflict with their facility (s) the locator or operator of the facility may notify the excavator of “No Conflict” by phone, fax, or email, or through the One-Call Center, where electronic positive response is used. Operators of multiple facilities would indicate a “No Conflict” for each facility as in the previous examples.
- Place “No Conflict” markings or flags in a location that can be observed by the excavator and or notify the excavator by phone, fax, or email that there is “No Conflict” with your facilities. When the excavation is delineated by the use of white markings, place “No Conflict” markings or flags in or as near as practicable to the delineated area.

\* Caution - Allow adequate space for all facility mark-outs.

“No Conflict” indicates; that the operator providing the “No Conflict” has no facilities within the scope of the delineation, or when there is no delineation, there are no facilities within the work area as described on the locate ticket.



### Color Code Identifiers

White	Proposed Excavation	Pink	Temporary Survey Markings
Red	Electric Power Lines, Cables, Conduit and Lighting Cables	Yellow	Gas, Oil, Steam, Petroleum or Gaseous Materials
Orange	Communication, Alarm or Signal Lines, Cables or Conduit	Blue	Potable Water
Purple	Reclaimed Water, Irrigation and Slurry Lines	Green	Sewers and Drain Lines

## Common Abbreviations:

### Facility Identifiers

CH	Chemical	SS	Storm Sewer
E	Electric	SL	Street Lighting
FO	Fiber Optic	STM	Steam
G	Gas	SP	Slurry System
LPG	Liquefied Petroleum Gas	TEL	Telephone
PP	Petroleum Products	TS	Traffic Signal
RR	Railroad Signal	TV	Television
S	Sewer	W	Water
SD	Storm Drain	W	Reclaimed Water "Purple"

### Underground Construction Descriptions

C	Conduit	HH	Hand Hole
CDR	Corridor	MH	Manhole
D	Distribution Facility	PB	Pull Box
DB	Direct Buried	R	Radius
DE	Dead End	STR	Structure (vaults, junction boxes, inlets, lift stations)
JT	Joint Trench	T	Transmission Facility
HP	High Pressure		

### Infrastructure Material

ABS	Acrylonitrile - Butadiene - Styrene	HDPE	High Density Polyethylene
ACP	Asbestos Cement Pipe	MTD	Multiple Tile Duct
CI	Cast Iron	PLA	Plastic (conduit or pipe)
CMC	Cement Mortar Coated	RCB	Reinforced Concrete Box
CML	Cement Mortar Lined	RCP	Reinforced Concrete Pipe
CPP	Corrugated Plastic Pipe	RF	Reinforced Fiberglass
CMP	Corrugated Metal Pipe	SCCP	Steel Cylinder Concrete Pipe
CU	Copper	STL	Steel
CWD	Creosote Wood Duct	VCP	Vertrified Clay Pipe

## **Guide for Abbreviation Use**

This is a guide for placing the above abbreviations in the field. The Company Identifier is to be placed at the top or at the left of the abbreviations. Place the abbreviations in the following order, Company Identifier / Facility Identifier / Underground Construction Descriptions / Infrastructure Material (e.g. SBC/TEL/FO/PLA). This example indicates that SBC has a Telecommunication Fiber Optic line in a single Plastic conduit. The use of the abbreviation /TEL is not necessary, because the orange marking would indicate that the facility was a communication line, but its use is optional. To leave out one or more of the abbreviation types you would continue to follow the order of the abbreviations above leaving out the slash and abbreviation that does not apply (e.g. /TEL), the result would be the following (e.g. SBC/FO/PLA).

---

### **CALIFORNIA BUSINESS AND PROFESSIONS CODE 7110**

#### **IN ASSEMBLY BILL FORM:**

#### **CONTRACTOR STATE LICENSE BOARD ENFORCEMENT Assembly Bill No. 2719**

An Act to amend Section 7110 of the Business and Professions Code, relating to contractors.

#### **LEGISLATIVE COUNSEL'S DIGEST**

AB2719, as amended, Frazee. Contractors.

Existing law provides that violation of specified laws by a licensed contractor constitutes cause for disciplinary action.

This bill would include within the specified laws provisions dealing with excavations and subsurface installations.

The people of the State of California do enact as follows:

**SECTION 1.** Section 7110 of the Business and Professions Code is amended to read:

7110. Willful or deliberate disregard and violation of the building laws of the state, or of any political subdivision thereof, or of the minimum painting standards adopted pursuant to Section 37040 of the Health and Safety Code, or of Section 8505 or 8556 of this code, or of Sections 1689.5 to 1689.8, inclusive, or Section 1689.10 to 1689.13, inclusive, of Civil Code, or of the safety laws or labor laws or compensation insurance laws or Unemployment Insurance Code of the state, or violation by any licensee of any provision of the Health and Safety Code or Water Code, relating to the digging, boring, or drilling of water wells, or Article 2 (commencing with Section 4216) of Chapter 3.1 of Division 5 of Title 1 of the Government Code, constitutes a cause for disciplinary action.

## **CALIFORNIA GOVERNMENT CODE 4216**

### **IN SENATE BILL FORM:**

### **SENATE BILL NO. 1359**

#### **CHAPTER 651**

An act to amend Sections 4216, 4216.2, 4216.3, 4216.4 and 4216.7 of the Government Code, relating to excavation around subsurface installations.

[Approved by Governor September 29, 2006. Filed with Secretary of State September 29, 2006.]

#### **LEGISLATIVE COUNSEL'S DIGEST**

SB 1359, Torlakson. Subsurface installations: excavations.

(1) Existing law requires planned excavations near subsurface installations to be conducted in a specified manner that protects the subsurface installations from damage. Existing law requires an excavator to determine the exact location of subsurface installations using specified tools. If the excavator still cannot locate the exact position of the installation, existing law then requires the excavator to request the operator to provide specified additional information to help determine the exact location of the installation. Existing law provides that an excavator who has failed to comply with regulations, as provided, is liable for any damages unless the owner or operator has not complied with regulations, as provided.

This bill would require the operator, if the excavation is within 10 feet of a high-priority subsurface installation, as defined, to notify the excavator of the installation, as specified, and to hold an onsite meeting with the operator to verify the location of the installation. This bill would allow only a qualified person, as defined, to perform subsurface installation locating activities, require a qualified person performing subsurface installation locating activities to use specified locating activities and devices, and require the operator to maintain plans for the subsurface installations. This bill also would require the regional notification center to provide an excavator with the operator's contact information and require an excavator to immediately notify the operator or 911 emergency services, if the operator cannot be contacted, when an excavator discovers or causes damage to a subsurface installation. This bill would also provide that any operator who fails to provide the position of a subsurface installation will be liable for any resulting costs, as specified, that the excavator may encounter as a result of the discrepancy. This bill would provide that an excavator will be liable for any resulting costs, as specified, for damages to a subsurface installa-

tion, for which the operator provided the position of, that are caused by the excavator.

(2) Existing law authorizes an excavator to determine the exact location of subsurface installations that are in conflict with the excavation before using any vacuum excavation devices or power-operated or power-driven excavating or boring equipment within the approximate location of the subsurface installation, provided there is an express written mutual agreement, as specified, and with a specified exception. If there is no express agreement, the excavator is required to use hand tools to determine the location of subsurface installations, as specified.

This bill would instead provide that, if documented notice of the intent to use vacuum excavation devices, or power-operated or power-driven excavating or boring equipment has been provided to the subsurface installation operator or operators and it is mutually agreeable to the operator or operators of the subsurface installation and the excavator, the excavator may use vacuum excavation devices or power-operated or power-driven excavating or boring tools within the approximate location of the subsurface installation.

*The people of the State of California do enact as follows:*

SECTION 1. Section 4216 of the Government Code is amended to read:

4216. As used in this article the following definitions apply:

(a) "Approximate location of subsurface installations" means a strip of land not more than 24 inches on either side of the exterior surface of the subsurface installation. "Approximate location" does not mean depth.

(b) "Excavation" means any operation in which earth, rock, or other material in the ground is moved, removed, or otherwise displaced by means of tools, equipment, or explosives in any of the following ways: grading, trenching, digging, ditching, drilling, augering, tunneling, scraping, cable or pipe plowing and driving, or any other way.

(c) Except as provided in Section 4216.8, "excavator" means any person, firm, contractor or subcontractor, owner, operator, utility, association, corporation, partnership, business trust, public agency, or other entity which, with their, or his or her, own employees or equipment performs any excavation.

(d) "Emergency" means a sudden, unexpected occurrence, involving a clear and imminent danger, demanding immediate action to prevent or mitigate loss of, or damage to, life, health, property, or essential public services. "Unexpected occurrence" includes, but is not limited to, fires, floods, earthquakes or other soil or geologic move-

ments, riots, accidents, damage to a subsurface installation requiring immediate repair, or sabotage.

(e) "High priority subsurface installation" means high-pressure natural gas pipelines with normal operating pressures greater than 415kPA gauge (60psig), petroleum pipelines, pressurized sewage pipelines, high-voltage electric supply lines, conductors, or cables that have a potential to ground of greater than or equal to 60kv, or hazardous materials pipelines that are potentially hazardous to workers or the public if damaged.

(f) "Inquiry identification number" means the number that is provided by a regional notification center to every person who contacts the center pursuant to Section 4216.2. The inquiry identification number shall remain valid for not more than 28 calendar days from the date of issuance, and after that date shall require regional notification center revalidation.

(g) "Local agency" means a city, county, city and county, school district, or special district.

(h) "Operator" means any person, corporation, partnership, business trust, public agency, or other entity that owns, operates, or maintains a subsurface installation. For purposes of Section 4216.1 an "operator" does not include an owner of real property where subsurface facilities are exclusively located if they are used exclusively to furnish services on that property and the subsurface facilities are under the operation and control of that owner.

(i) "Qualified person" means a person who completes a training program in accordance with the requirements of Title 8, California Code of Regulations, Section 1509, Injury Prevention Program, that meets the minimum training guidelines and practices of Common Ground Alliance current Best Practices.

(j) "Regional notification center" means a nonprofit association or other organization of operators of subsurface installations that provides advance warning of excavations or other work close to existing subsurface installations, for the purpose of protecting those installations from damage, removal, relocation, or repair.

(k) "State agency" means every state agency, department, division, bureau, board, or commission.

(l) "Subsurface installation" means any underground pipeline, conduit, duct, wire, or other structure, except nonpressurized sewerlines, nonpressurized storm drains, or other nonpressurized drain lines.

4216.1. Every operator of a subsurface installation, except the Department of Transportation, shall become a member of, participate in, and share in the costs of, a regional notification center. Operators of subsurface installations who are members of, participate in, and share in, the costs of a regional notification center, including, but not limited to, the South Shore Utility Coordinat-

ing Council, the Underground Service Alert–Northern California or the Underground Service Alert–Southern California are in compliance with this section and Section 4216.9.

4216.2. (a) (1) Except in an emergency, any person planning to conduct any excavation shall contact the appropriate regional notification center, at least two working days, but not more than 14 calendar days, prior to commencing that excavation, if the excavation will be conducted in an area that is known, or reasonably should be known, to contain subsurface installations other than the underground facilities owned or operated by the excavator and, if practical, the excavator shall delineate with white paint or other suitable markings the area to be excavated.

(2) When the excavation is proposed within 10 feet of a high priority subsurface installation, the operator of the high priority subsurface installation shall notify the excavator of the existence of the high priority subsurface installation prior to the legal excavation start date and time, as such date and time are authorized pursuant to paragraph (1) of subdivision (a) of Section 4216.2. The excavator and operator or its representative shall conduct an onsite meeting at a mutually-agreed-on time to determine actions or activities required to verify the location of the high priority subsurface installations prior to start time.

(b) Except in an emergency, every excavator covered by Section 4216.8 planning to conduct an excavation on private property may contact the appropriate regional notification center if the private property is known, or reasonably should be known, to contain a subsurface installation other than the underground facility owned or operated by the excavator and, if practical, the excavator shall delineate with white paint or other suitable markings the area to be excavated.

(c) The regional notification center shall provide an inquiry identification number to the person who contacts the center pursuant to this section and shall notify any member, if known, who has a subsurface installation in the area of the proposed excavation. An inquiry identification number may be validated for more than 28 days when mutually agreed between the excavator and any member operator so notified that has a subsurface installation in the area of the proposed excavation; and, it may be revalidated by notification to the regional notification center by the excavator prior to the time of its expiration.

(d) A record of all notifications by excavators and operators to the regional notification center shall be maintained for a period of not less than three years. The record shall be available for inspection by the excavator and any member, or their representative, during normal working hours and according to guidelines for inspection

as may be established by the regional notification centers.

(e) As used in this section, the delineation is practical when any of the following conditions exist:

(1) When delineating a prospective excavation site with white paint could not be misleading to those persons using affected streets and highways.

(2) When the delineation could not be misinterpreted as a traffic or pedestrian control.

(3) Where an excavator can determine the exact location of an excavation prior to the time an area has been field marked pursuant to Section 4216.3.

(4) Where delineation could not be construed as duplicative.

(f) Where an excavator makes a determination that it is not practical to delineate the area to be excavated, the excavator shall contact the regional notification center to advise the operators that the excavator shall identify the area to be excavated in another manner sufficient to enable the operator to determine the area of the excavation to be field marked pursuant to Section 4216.3.

4216.3. (a) (1) Any operator of a subsurface installation who receives timely notification of any proposed excavation work in accordance with Section 4216.2 shall, within two working days of that notification, excluding weekends and holidays, or before the start of the excavation work, whichever is later, or at a later time mutually agreeable to the operator and the excavator, locate and field mark the approximate location and, if known, the number of subsurface installations that may be affected by the excavation to the extent and degree of accuracy that the information is available either in the records of the operator or as determined through the use of standard locating techniques other than excavating, otherwise advise the person who contacted the center of the location of the operator's subsurface installations that may be affected by the excavation, or advise the person that the operator does not operate any subsurface installations that would be affected by the proposed excavation.

(2) Only a qualified person shall perform subsurface installation locating activities.

(3) A qualified person performing subsurface installation locating activities on behalf of a subsurface installation operator shall use a minimum of a single-frequency utility locating device and shall have access to alternative sources for verification, if necessary.

(4) Operators of high priority subsurface installations shall maintain and preserve all plans and records for its subsurface installations.

(b) Every operator of a subsurface installation who field marks the location of a subsurface installation shall make a reasonable effort to make field markings in confor-

mance with the uniform color code of the American Public Works Association.

(c) If, at any time during an excavation for which there is a valid inquiry identification number, an operator's field markings are no longer reasonably visible, the excavator shall contact the appropriate regional notification center. The regional notification center shall contact any member, if known, who has a subsurface installation in the area of the excavation. Upon receiving timely notification or renotification pursuant to this subdivision, the operator shall re-locate and re-mark, within two working days, those subsurface installations that may be affected by the excavation to the extent necessary, in conformance with this section.

(d) The excavator shall notify the appropriate regional notification center of the failure of an operator to comply with this section. The notification shall include the inquiry identification number issued by the regional notification center. A record of all notifications received pursuant to this subdivision shall be maintained by the regional notification center for a period of not less than three years. The record shall be available for inspection pursuant to subdivision (d) of Section 4216.2.

4216.4. (a) When the excavation is within the approximate location of subsurface installation, the excavator shall determine the exact location of subsurface installations in conflict with the excavation by excavating with hand tools within the area of the approximate location of subsurface installations as provided by the operators in accordance with Section 4216.3 before using any power-operated or power-driven excavating or boring equipment within the approximate location of the subsurface installation, except that power-operated or power-driven excavating or boring equipment may be used for the removal of any existing pavement if there are no subsurface installations contained in the pavement. If documented notice of the intent to use vacuum excavation devices, or power-operated or power-driven excavating or boring equipment, has been provided to the subsurface installation operator or operators and it is mutually agreeable with the operator or operators and the excavator, the excavator may utilize vacuum excavation devices, or power-operated or power-driven excavating or boring equipment within the approximate location of a subsurface installation and to any depth.

(b) If the exact location of the subsurface installation cannot be determined by hand excavating in accordance with subdivision (a), the excavator shall request the operator to provide additional information to the excavator, to the extent that information is available to the operator, to enable the excavator to determine the exact location of the installation. The regional notification center shall pro-

vide the excavator with the contact phone number of the subsurface installation operator.

(c) An excavator discovering or causing damage to a subsurface installation, including all breaks, leaks, nicks, dents, gouges, grooves, or other damage to subsurface installation lines, conduits, coatings, or cathodic protection, shall immediately notify the subsurface installation operator. The excavator may contact the regional notification center to obtain the contact information of the subsurface installation operator. If high priority subsurface installations are damaged and the operator cannot be contacted, the excavator shall call 911 emergency services.

4216.5. The requirements of this article apply to state agencies and to local agencies which own or operate subsurface installations, except as otherwise provided in Section 4216.1. A local agency which is required to provide the services described in Section 4216.3 may charge a fee in an amount sufficient to cover the cost of providing that service.

4216.6. (a) (1) Any operator or excavator who negligently violates this article is subject to a civil penalty in an amount not to exceed ten thousand dollars (\$10,000).

(2) Any operator or excavator who knowingly and willfully violates any of the provisions of this article is subject to a civil penalty in an amount not to exceed fifty thousand dollars (\$50,000).

(3) Except as otherwise specifically provided in this article, this section is not intended to affect any civil remedies otherwise provided by law for personal injury or for property damage, including any damage to subsurface installations, nor is this section intended to create any new civil remedies for those injuries or that damage.

(4) This article shall not be construed to limit any other provision of law granting governmental immunity to state or local agencies or to impose any liability or duty of care not otherwise imposed by law upon any state or local agency.

(b) An action may be brought by the Attorney General, the district attorney, or the local or state agency which issued the permit to excavate, for the enforcement of the civil penalty pursuant to this section. If penalties are collected as a result of a civil suit brought by a state or local agency for collection of those civil penalties, the penalties imposed shall be paid to the general fund of the agency. If more than one agency is involved in enforcement, the penalties imposed shall be apportioned among them by the court in a manner that will fairly offset the relative costs incurred by the state or local agencies, or both, in collecting these fees.

4216.7 (a) If a subsurface installation is damaged by an excavator as a result of failing to comply with Section

4216.2 or 4216.4, or as a result of failing to comply with the operator's requests to protect the subsurface installation as specified by the operator prior to the start of excavation, the excavator shall be liable to the operator of the subsurface installation for resulting damages, costs, and expenses to the extent the damages, costs, and expenses were proximately caused by the excavator's failure to comply.

(b) If the operator of a subsurface installation has failed to comply with the regional notification center system requirements of Section 4216.1, that operator shall forfeit his or her claim for damages to his or her subsurface installation, arising from the excavation, against an excavator who has complied with the requirements of Section 4216.2 to the extent damages were proximately caused by the operator's failure to comply.

(c) If an operator of a subsurface installation has failed to comply with the provisions of Section 4216.3, has failed to comply with paragraph (2) of subdivision (a) of Section 4216.2, or has failed to comply with subdivision (b) of Section 4216.4, the operator shall be liable to the excavator who has complied with Sections 4216.2 and 4216.4 for damages, costs, and expenses resulting from the operator's failure to comply with these specified requirements to the extent the damages, costs, and expenses were proximately caused by the operator's failure to comply.

(d) Nothing in this section shall be construed to do any of the following:

(1) Affect claims including, but not limited to, third-party claims brought against the excavator or operator by other parties for damages arising from the excavation.

(2) Exempt the excavator or operator from his or her duty to mitigate any damages as required by common or other applicable law.

(3) Exempt the excavator or operator from liability to each other or third parties based on equitable indemnity or comparative or contributory negligence.

4216.8. This article does not apply to any of the following persons:

(a) An owner of real property who contracts for an excavation project on the property, not requiring a permit issued by a state or local agency, with a contractor or subcontractor licensed pursuant to Article 5 (commencing with Section 7065) of Chapter 9 of Division 3 of the Business and Professions Code.

(b) An owner of residential real property, not engaged as a contractor or subcontractor licensed pursuant to Article 5 (commencing with Section 7065) of Chapter 9 Division 3 of the Business and Professions Code, who as part of improving his or her principal residence or appurtenances thereto is performing or having performed ex-

cavation work not requiring a permit issued by a state or local agency.

(c) Any person or private entity that leases or rents power operated or power-driven excavating or boring equipment, regardless of whether an equipment operator is provided for that piece of equipment or not, to a contractor or subcontractor licensed pursuant to Article 5 (commencing with Section 7065) of Chapter 9 of Division 3 of the Business and Professions Code, if the signed rental agreement between the person or private entity and the contractor or subcontractor contains the following provision: "It is the sole responsibility of the lessee or renter to follow the requirements of the regional notification center law pursuant to Article 2 (commencing with Section 4216) of Chapter 3.1 of Division 5 of Title 1 of the Government Code. By signing this contract, the lessee or renter accepts all liabilities and responsibilities contained in the regional notification center law."

4216.9. (a) No permit to excavate issued by any local agency, as defined in Section 4216, or any state agency, shall be valid unless the applicant has been provided an initial inquiry identification number by a regional notification center pursuant to Section 4216.2. For purposes of this section, "state agency" means every state agency, department, division, bureau, board, or commission, including the Department of Transportation.

(b) This article does not exempt any person or corporation from Sections 7951, 7952, and 7953 of the Public Utilities Code.

SEC. 5. Section 4217 of the Government Code is repealed.

---

**CalOSHA Title 8**  
**Construction Safety Orders**  
**Chapter 4, Subchapter 4, Article 6, Section 1541**

Effective March 31, 2007

**§1541. General Requirements.**

(a) Surface encumbrances. All surface encumbrances that are located so as to create a hazard to employees shall be removed or supported, as necessary, to safeguard employees.

(b) Subsurface installations.

(1) The approximate location of subsurface installations, such as sewer, telephone, fuel, electric, water lines, or any other subsurface installations that reasonably may be expected to be encountered during excavation work, shall be determined by the excavator prior to opening an excavation.

(A) Excavation shall not commence until:

1. The excavation area has been marked as specified in Government Code Section 4216.2 by the excavator; and

2. The excavator has received a positive response from all known owner/operators of subsurface installations within the boundaries of the proposed project; those responses confirm that the owner/operators have located their installations, and those responses either advise the excavator of those locations or advise the excavator that the owner/operator does not operate a subsurface installation that would be affected by the proposed excavation.

(B) When the excavation is proposed within 10 feet of a high priority subsurface installation, the excavator shall be notified by the facility owner/operator of the existence of the high priority subsurface installation before the legal excavation start date and time in accordance with Government Code Section 4216.2(a), and an onsite meeting involving the excavator and the subsurface installation owner / operator's representative shall be scheduled by the excavator and the owner / operator at a mutually agreed on time to determine the action or activities required to verify the location of such installations. High priority subsurface installations are high pressure natural gas pipelines with normal operating pressures greater than 415 kPA gauge (60 p.s.i.g.), petroleum pipelines, pressurized sewage pipelines, conductors or cables that have a potential to ground of 60,000 volts or more, or hazardous materials pipelines that are potentially hazardous to employees, or the public, if damaged.

(C) Only qualified persons shall perform subsurface installation locating activities, and all such activities shall be performed in accordance with this section and Government Code Sections 4216 through 4216.9. Persons who complete a training program in accordance with the requirements of Section 1509, Injury and Illness Prevention Program (IIPP), that meets the minimum training guidelines and practices of the Common Ground Alliance (CGA) Best Practices, Version 3.0, published March 2006, or the standards of the National Utility Locating Contractors Association (NULCA), Standard 101: Professional Competence Standards for Locating Technicians, 2001, First Edition, which are incorporated by reference, shall be deemed qualified for the purpose of this section.

(D) Employees who are involved in the excavation operation and exposed to excavation operation hazards shall be trained in the excavator notification and excavation practices required by this section and Government Code Sections 4216 through 4216.9.

(2) All Regional Notification Centers as defined by Government Code Section 4216(j) in the area involved and all known owners of subsurface facilities in the area who are not members of a Notification Center shall be advised of the proposed work at least 2 working days prior to the start of

any digging or excavation work. EXCEPTION: Repair work to subsurface facilities done in response to an emergency as defined in Government Code Section 4216(d).

(3) When excavation or boring operations approach the approximate location of subsurface installations, the exact location of the installations shall be determined by safe and acceptable means that will prevent damage to the subsurface installation, as provided by Government Code Section 4216.4.

(4) While the excavation is open, subsurface installations shall be protected, supported, or removed as necessary to safeguard employees.

(5) An excavator discovering or causing damages to a subsurface installation shall immediately notify the facility owner/operator or contact the Regional Notification Center to obtain subsurface installation operator contact information immediately after which the excavator shall notify the facility operator. All breaks, leaks, nicks, dents, gouges, grooves, or other damages to an installation's lines, conduits, coatings or cathodic protection shall be reported to the subsurface installation operator. If damage to a high priority subsurface installation results in the escape of any flammable, toxic, or corrosive gas or liquid or endangers life, health or property, the excavator responsible shall immediately notify 911, or if 911 is unavailable, the appropriate emergency response personnel having jurisdiction. The facility owner/operator shall also be contacted.

Note: The terms excavator and operator as used in Section 1541(b) shall be as defined in Government Code Section 4216(c) and (h) respectively. The term "owner / operator" means an operator as the term "operator" is defined in Government Code Section 4216(h).



**USA North's**  
**California Excavation Manual**

**811 / 1-800-227-2600**



**Know what's below.  
Call before you dig.**

**USA North (Underground Service Alert)**  
4090 Nelson Avenue, Suite A, Concord, CA. 94520-1232  
Administrative: Phone 925-798-9504; Fax 925-798-9506;  
Web Page: [www.usanorth.org](http://www.usanorth.org)

**This manual is provided to you as a public service by  
USA North and is dedicated to the safety of our  
communities in California and Nevada.**

**Know what's below.  
Call 2 Working Days To 14 Calendar Days  
Before You Dig in California and Nevada!**

Revised 01/01/09 ©